

# *Owner's Manual*



**SKv2-1500.1D**

**SKv2-2500.1D**

**SKv2-3500.1D**

**SKv2-4500.1D**

**SKv2-1300.2AB**

**SKv2-100.4AB**

**SKv2-200.4D**

**SOUND QUALITY AMPLIFIER**

## 1. INTRODUCTION

Congratulations and thank you for purchasing Skar audio amplifiers, the logical choice in mobile audio amplification. Your amplifiers have been designed and engineered with the highest quality components and top of the line workmanship to help you reach the superior sound you are after. To achieve optimal performance of your system, please take a few moments to read over this Owner's manual or visit authorized dealer if needed before starting your installation.

## 2. DESIGN FEATURES

Strappable, high power and efficient digital monoblock amplifiers

- @ Stable into 1ohm load for monoblock and Skv2-1300.2AB
- @ Stable into 2ohm stereo for Skv2-100.4AB Skv2-200.4D
- @ Full range digital circuit for Skv2-200.4D
- @ High speed mosfet power supply
- @ 24dB/Oct. Variable Crossover for Digital monoblock amplifiers
- @ Variable bass boost
- @ 180 degree variable phase control
- @ Remote control with clipping LED included
- @ 4 way protection circuit ( Thermal, High & Low voltage, Speaker short & DC )
- @ High Purity copper printed boards
- @ 4 & 0 gauge power & ground terminals
- @ Hand-made high grade power supply

## 3. SPECIFICATIONS

### 3-1. Digital monoblock specifications

| FEATURES                      | SKv2-1500.1D | SKv2-2500.1D | SKv2-3500.1D | SKv2-4500.1D |
|-------------------------------|--------------|--------------|--------------|--------------|
| Power @ 4ohm                  | 500W x 1     | 790W x 1     | 1200W x 1    | 1500W x 1    |
| Power @ 2ohm                  | 930W x 1     | 1450W x 1    | 2050W x 1    | 2800W x 1    |
| Power @ 1ohm                  | 1700W x 1    | 2500W x 1    | 3500W x 1    | 4900W x 1    |
| Strappable Power              |              |              |              |              |
| Power @ 4ohm                  | 1860W x 1    | 2900W x 1    | 4100W x 1    | 5600W x 1    |
| Power @ 2ohm                  | 3400W x 1    | 5000W x 1    | 7000W x 1    | 9800W x 1    |
| Frequency Response            | 15~270Hz     | 15~270Hz     | 15~270Hz     | 15~270Hz     |
| Signal to Noise Ratio         | 95dB         | 95dB         | 95dB         | 95dB         |
| Damping Factor                | 200 <        | 200 <        | 200 <        | 200 <        |
| Input Sensitivity             | 6V~0.2V      | 6V~0.2V      | 6V~0.2V      | 6V~0.2V      |
| Low Pass Filter               | 35~250Hz     | 35~250Hz     | 35~250Hz     | 35~250Hz     |
| Subsonic Filter               | 10~50Hz      | 10~50Hz      | 10~50Hz      | 10~50Hz      |
| Bass Boost ( @ 45Hz )         | 0~9dB        | 0~9dB        | 0~9dB        | 0~9dB        |
| Phase Shift ( Degree )        | 0~180        | 0~180        | 0~180        | 0~180        |
| Master / Slave connection     | to 2ohm      | to 2ohm      | to 2ohm      | to 2ohm      |
| Remote Gain Control           | Included     | Included     | Included     | Included     |
| Power & Ground terminals.     | 0 Ga         | 0 Ga         | 0 Ga         | 0 Gax2pcs    |
| Working Voltage               | 8.5V~16V     | 8.5V~16V     | 8.5V~16V     | 8.5V~18V     |
| External Fuse ( Single Unit ) | 160A         | 250A         | 350A         | 450A         |
| External Fuse ( Strappable )  | 320A         | 500A         | 700A         | 900A         |

All features are subject to change in the continuing effort to improve the products without notice.

### 3-2. Multi-channels specification

| FEATURES                   | SKv2-1300.2AB | SKv2-100.4AB | SKv2-200.4D  |
|----------------------------|---------------|--------------|--------------|
| Power @ 4ohm               | 330W x 2      | 110W x 4     | 200W x 4     |
| Power @ 2ohm               | 530W x 2      | 165W x 4     | 320W x 4     |
| Power @ 1ohm               | 700W x 2      | na           | na           |
| Power @ 4ohm mono          | 1060W x 1     | 340W x 2     | 640W x 2     |
| power @ 2ohm mono          | 1400W x 1     | na           | na           |
| Frequency Response         | 10Hz~40KHz    | 10Hz~40KHz   | 10Hz~40KHz   |
| Signal to Noise Ratio      | 105dB         | 105dB        | 85dB         |
| Damping Factor             | 200 <         | 200 <        | 200 <        |
| Input Sensitivity          | 6V-0.2V       | 6V-0.2V      | 6V-0.2V      |
| Subsonic Filter            | na            | 10Hz~500Hz   | 10Hz~500Hz   |
| High Pass Filter           | 20Hz~5KHz     | 50Hz~500Hz   | 50Hz~500Hz   |
| High Pass Multiply ( x10 ) | na            | 500Hz~5KHz   | 500Hz~5KHz   |
| Low Pass Filter            | 50Hz~5KHz     | 50Hz~500Hz   | 50Hz~500Hz   |
| Low Pass Multiply ( x10 )  | na            | 500Hz~5KHz   | 500Hz~5KHz   |
| Crossover Selector         | ON / OFF      | HPF/FULL/LPF | HPF/FULL/LPF |
| Bass Boost ( @ 45Hz )      | na            | na           | na           |
| Remote Gain Control        | Included      | Included     | Included     |
| Power & Ground terminals.  | 0Ga           | 4Ga          | 4Ga          |
| Working Voltage            | ~14.4V        | ~14.4V       | ~14.4V       |
| Fuse Rate                  | 200A          | 30A x 3      | 40A x 2      |

All features are subject to change in the continuing effort to improve the products without notice.

## 4. CONTROLS & CONNECTIONS

### 4-1. Digital monoblock control

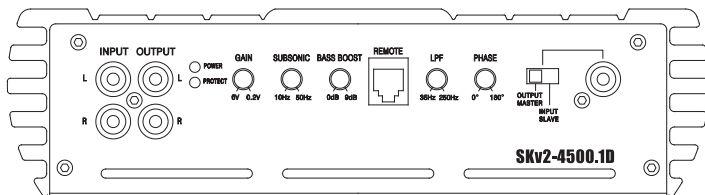

#### RCA JACK INPUT

Low Level Rca Input will accept the signal from the output of head units. Plug in Rca jack cables from the head unit.

#### RCA JACK OUTPUT

The preamp output is a full range signal mixed from both input channels. Use this signal to feed a secondary full range amplifier in the system.

#### POWER & PROTECTION LED

Power LED, Green-lit shows correct operation. Protect LED, RED-lits shows general malfunction, faulty connection and thermal protection.

#### GAIN CONTROL ( 6V - 0.2V )

The gain control adjusts the gain level, so that this is used to match the signal level of different headunits.

#### SUBSONIC FILTER ( 10Hz - 50Hz @ 24dB / Oct slope )

Control the high Pass point for the speaker outputs to eliminate extreme low frequencies.

#### BASS BOOST ( 0 - 9dB @ 45Hz )

It adjusts for up to 9dB of additional gain at that frequency.

#### REMOTE CONTROL PORT

When using the remote control in a multi amp system the remote of the master amp will control all amps in the system. Remote control can be mounted around driver's seat for easy access.

#### LOW PASS FILTER ( 35Hz - 250Hz @ 24dB / Oct slope )

The crossover features a steep 24dB oct slope Linkwitz-Riley low pass crossover ensuring that only the lowest frequencies are reproduced by the amplifier.

#### PHASE SHIFT ( 0 - 180 degrees )

The adjustable Phase control will help fine tune your bass system to time align with your midrange and high frequency speakers.

#### OUTPUT MASTER / INPUT SLAVE CONNECTION

Output Master / Input Slave connection makes chain connection to minimum impedance 2 ohm.

## 4-2. 2channel control

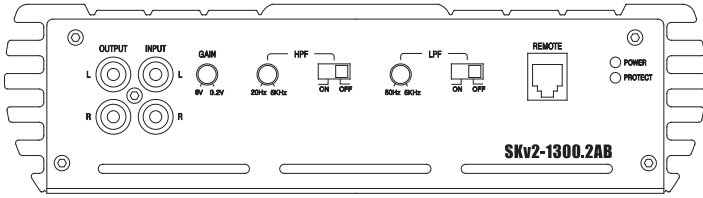

### RCA JACK INPUT

Low Level Rca Input will accept the signal from the output of head units. Plug in Rca jack cables from the head unit.

### RCA JACK OUTPUT

The preamp output is a full range signal mixed from both input channels. Use this signal to feed a secondary full range amplifier in the system.

### GAIN CONTROL ( 6V ~ 0.2V )

The gain control adjusts the gain level, so that this is used to match the signal level of different headunits.

### HIGH PASS FILTER ( 20Hz ~ 5KHz @ 12dB / Oct slope )

The crossover features a steep 12dB oct slope Linkwitz-Riley high pass crossover ensuring that only the highest frequencies are reproduced by the amplifier.

### X-OVER SELECTOR SWITCH ( ON / OFF )

Selected x-over is in effective.

### LOW PASS FILTER ( 50Hz ~ 5KHz @ 12dB / Oct slope )

The crossover features a steep 12dB oct slope Linkwitz-Riley low pass crossover ensuring that only the lowest frequencies are reproduced by the amplifier.

### REMOTE CONTROL PORT

Plug remote controller to this port for remote gain control Remote control can be mounted around driver's seat for easy access.

### POWER & PROTECTION LED

Power LED, Green-lit shows correct operation. Protect LED, RED-lits shows general malfunction, faulty connection and thermal protection.

## 4-3. 4channel control

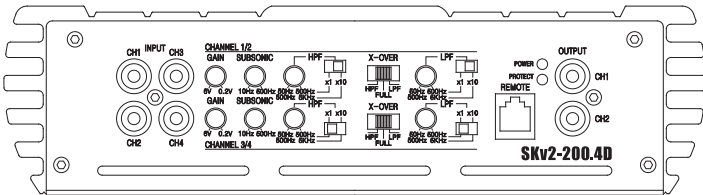

### RCA JACK INPUT

Low Level Rca Input will accept the signal from the output of head units. Plug in Rca jack cables from the head unit.

### RCA JACK OUTPUT

The preamp output is a full range signal mixed from both input channels. Use this signal to feed a secondary full range amplifier in the system.

### GAIN CONTROL ( 6V ~ 0.2V )

The gain control adjusts the gain level, so that this is used to match the signal level of different headunits.

### SUBSONIC FILTER ( 10Hz ~ 500Hz @ 12dB / Oct slope )

Control the high pass point for the speaker outputs to eliminate extreme low frequencies.

### HIGH PASS FILTER ( 50Hz ~ 500Hz @ 12dB / Oct slope )

The crossover features a steep 12dB oct slope Linkwitz-Riley high pass crossover ensuring that only the highest frequencies are reproduced by the amplifier.

### MULTIPLY ( X1, X10 )

This x10 makes crossover range from 500Hz to 5KHz.

### X-OVER SELECTOR SWITCH ( HPF/FULL/LP )

Selected x-over is in effective.

### LOW PASS FILTER ( 50Hz ~ 500Hz @ 12dB / Oct slope )

The crossover features a steep 12dB oct slope Linkwitz-Riley low pass crossover ensuring that only the lowest frequencies are reproduced by the amplifier.

### REMOTE CONTROL PORT

Plug remote controller to this port for remote gain control Remote control can be mounted around driver's seat for easy access.

### POWER & PROTECTION LED

Power LED, Green-lit shows correct operation. Protect LED, RED-lits shows general malfunction, faulty connection and thermal protection.

#### 4-4. Power, remote & ground connection

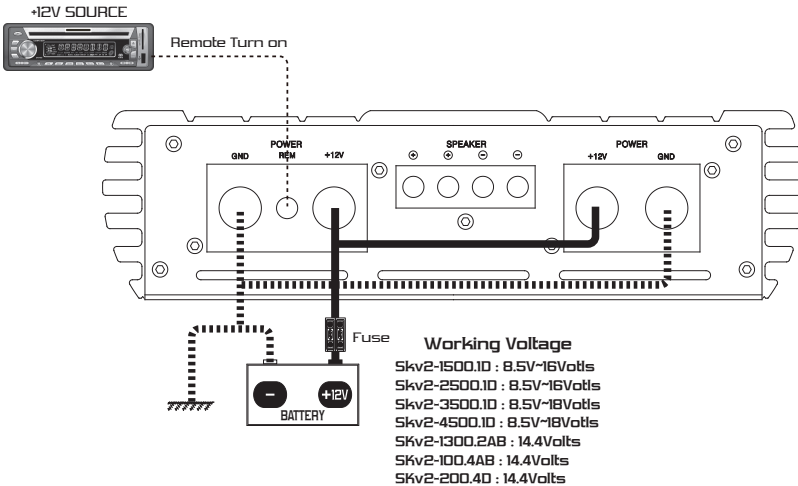

#### GND ( GROUND )

Locate a secure grounding connection as close to amplifier as possible.

Make sure the location is clean and provides a direct electrical connection to the frame of the vehicle.

The ground needs to have as low of a resistance as possible.

Connect one end of a short piece of the same size cable as the power cable to the grounding point or to one of your batteries or battery bank.

Run the other end of the 0 or 4 gauge cable to the mounting location of the amplifiers for connection to the amplifiers ground terminals and connect the ground cable to the GND ( ground terminal ).

#### REM ( REMOTE )

Run a remote turn on cable from the switched +12V source . This may be a toggle switch, a relay,

your source unit's remote trigger cables, or power antenna trigger cable. Connect the remote turn on cable to the REM ( remote ) terminal.

#### 12V ( POWER CONNECTION )

Before mounting amplifiers, disconnect the negative ( - ) cable from the battery to protect any accidental damage to your awesome amplifiers and audio system.

All amplifiers are designed to use 4 or 0 gauge power and ground connection.

Connect the power cables to power terminal +12V.

SKv2-100.4AB and SKv2-200.4D have built-in fuses but The other amplifiers are not equipped with fuses so that external fuses should be used.

Connect one end of fuse holder to the power cable going into the amplifiers and the other end of fuse holder to positive battery.

This fuse location will protect the system and the vehicle against the possibility of a short circuit in the power cable. Be sure to use fuses and fuse holder adequate for the application.

#### SPEAKER OUTPUT

This terminal connects the amplifiers to the speaker systems. Minimum speaker cable should be larger than 12 gauge.

Connect carefully the subwoofer speakers by checking the impedance 1ohm or 2ohm for link connection to SKv2-1500.1D, SKv2-2500.1D, SKv2-3500.1D & SKv2-4500.1D.

SKv2-1300.2AB as 1ohm stereo or 2ohm mono stable.

SKv2-100.4AB and SKv2-200.4D as 2ohm stereo or 4ohm mono stable.

## 4-5. Seaker connection

### Digital monoblock speaker connection 1.

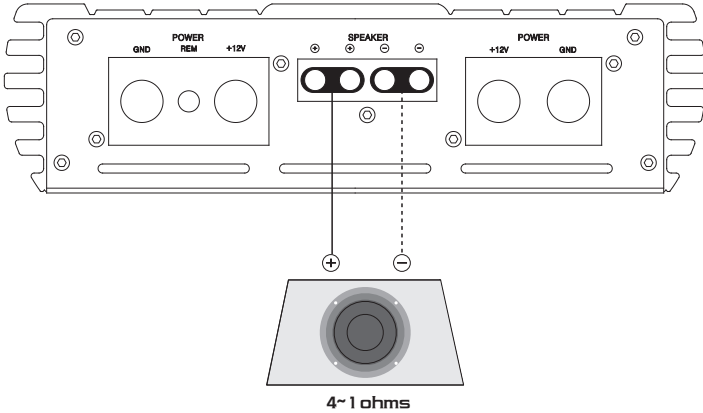

### Caution !!

Skv2-1500.10, Skv2-2500.10, Skv2-3500.10 and Skv2-4500.10 Minimum working impedance is 1ohm as single unit. Impedance lower than 1ohm can damage the amplifiers

### Digital monoblock speaker connection 2

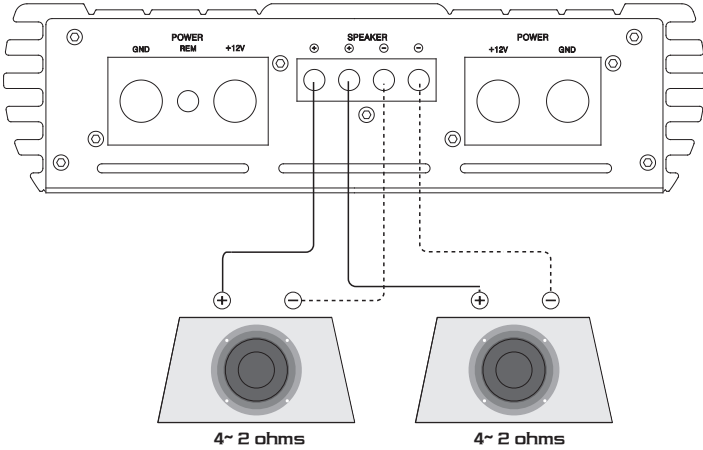

SKv2-1300AB speaker connection 1.

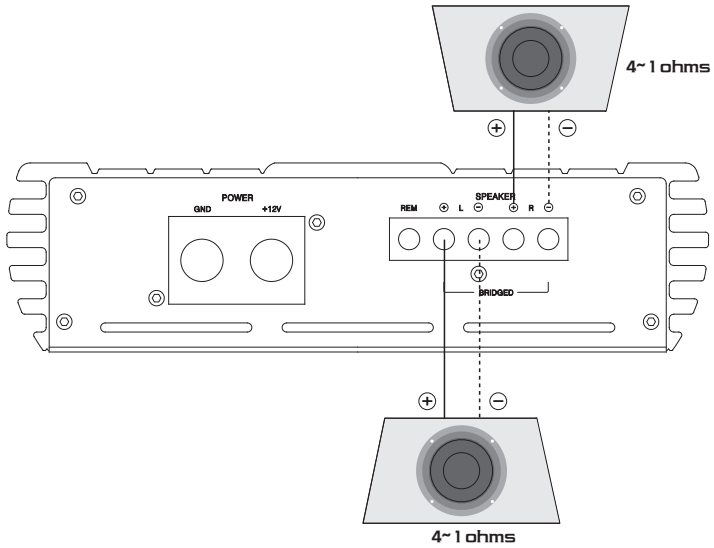

**Caution !!**

SKv2-1300.2 Minimum working impedance is 1ohm stereo or 2ohm mono.

SKv2-1300AB speaker connection 2.

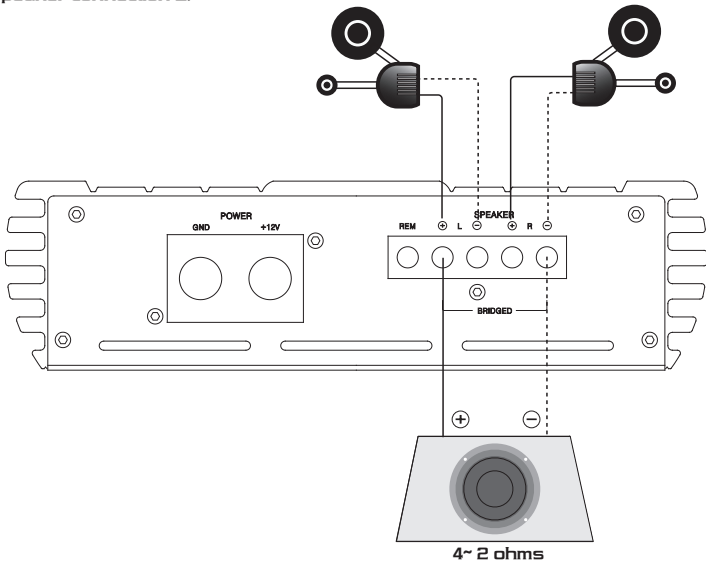

#### 4channel speaker connection 1.

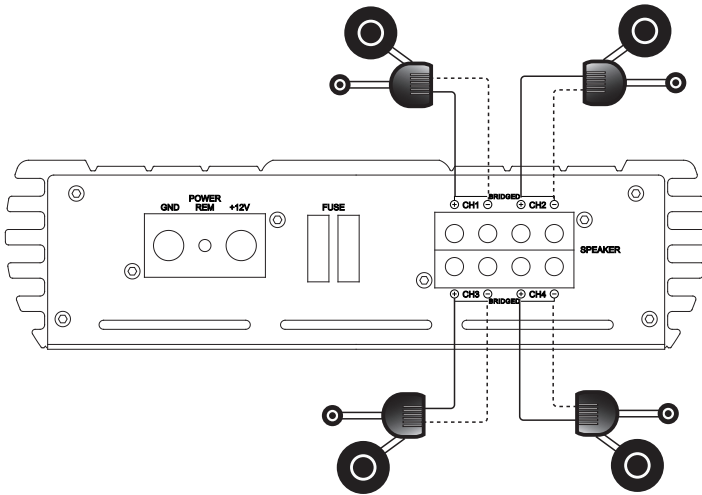

#### Caution !!

5Kv2-100.4AB & 5Kv2-200.4D Minimum working impedance is 2ohm STEREO or 4ohm mono.

#### 4channel speaker connection 12.

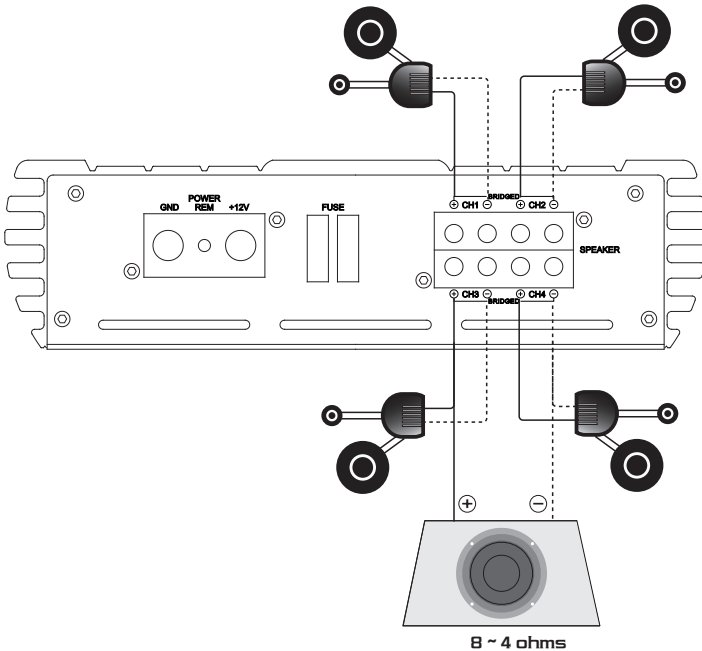



## 5. Strappable connection

Strappable connection makes two of same amplifiers linked to 2ohm.

Strappable connection makes the power double than their's each 1ohm power.

Please read the following connection and diagram carefully to make correct connection.

### INPUT CONNECTION :

Step 1. Connect the Master amplifier to the head-unit and set its output master / input slave switch to output master.

Step 2. Set Slave amplifier output master / input slave switch to slave input.

Step 3. Connect RCA cable from the master to slave amplifier as shown in the diagram.

### POWER & SPEAKER CONNECTION :

Step 1. Connect speaker cable (+) on master amplifier to subwoofer (+)

Step 2. Connect speaker cable (+) on slave amplifier to subwoofer (-)

Step 3. Connect speaker cable (-) on master amplifier to speaker cable (-) on slave amplifier

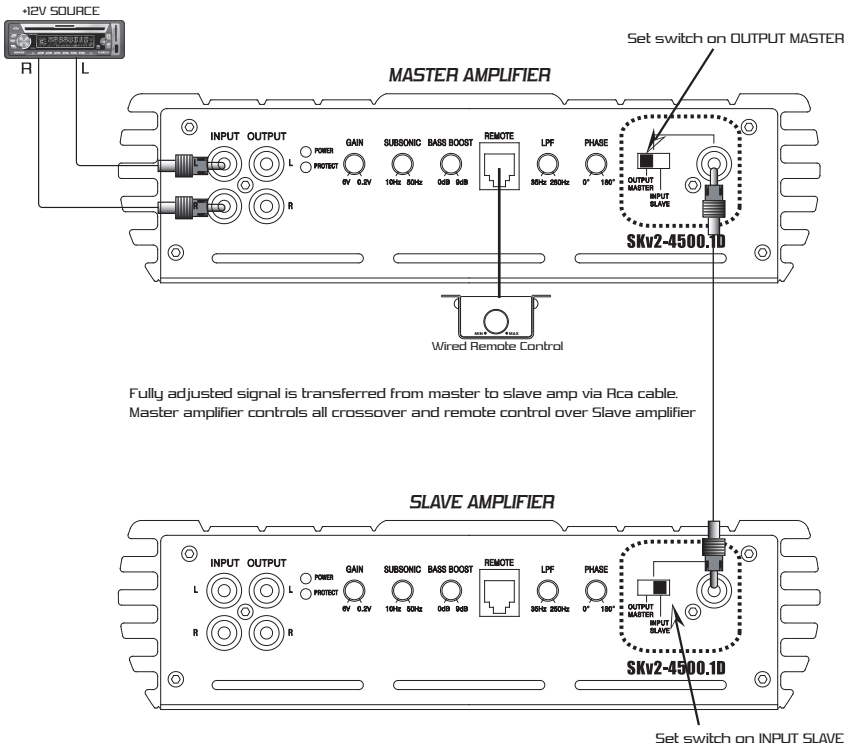

+12V SOURCE



Remote turn on

### MASTER AMPLIFIER

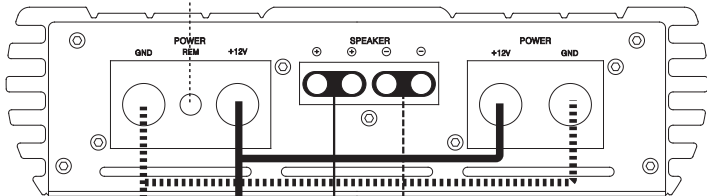

Ground



Connect Positive of master amp's terminal to Positive of Subwoofer's terminal

Connect Positive of slave amp's terminal to Negative of Subwoofer's terminal

Connect negative of master amp's terminal to Negative of slave amp's terminal

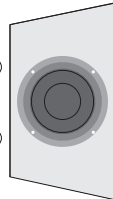

8 - 2 ohms

### SLAVE AMPLIFIER

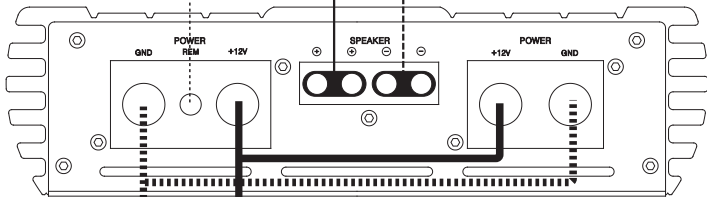

Ground



| Working Voltage |                  |
|-----------------|------------------|
| SKv2-1500.1D    | : 8.5V - 16Volts |
| SKv2-2500.1D    | : 8.5V - 16Volts |
| SKv2-3500.1D    | : 8.5V - 18Volts |
| SKv2-4500.1D    | : 8.5V - 18Volts |

### Caution !!

In strappable connection,

Minimum working impedance is 2ohm.  
Impedance lower than 2ohm can damage the amplifiers

## 6. Trouble shooting

### NO SOUND ( NO OUTPUT )

- Ⓜ Please check all connections, cables' routing, short & voltage
- Ⓜ Please check the fuses . If they are blown, please replace with new one.
- Ⓜ Please check whether speakers work well, you can test speakers by connecting to another amplifier

### PROTECTION

- Ⓜ Please check overload, overheat ( thermal ), short and voltage, DC offset.
- Ⓜ Minimum working impedance is 1 ohm for SKv2-1500.1D, SKv2-2500.1D, SKv2-3500.1D & SKv2-4500.1D as single unit and 2 ohm stable for strappable connection.  
SKv2-1300.2AB is 1ohm stereo or 2ohm mono.  
SKv2-100.4AB & SKv2-200.4D is 2ohm stereo or 4ohm mono.
- Ⓜ If amplifiers are shut down due to heat, they will be on some minutes later after cooling down.  
Please make better airflow and no obstruction around amplifiers for thermal protection.
- Ⓜ SKv2-1500.1D & SKv2-2500.1D's working voltage is 8.5 ~ 16Volts.  
SKv2-3500.1D & SKv2-4500.1D's working voltage is 8.5 ~ 18Volts  
SKv2-1300.2AB, SKv2-100.4AB & SKv2-200.4D are working to 14.4Volts
- Ⓜ When over 4V DC comes into amplifiers, then, they will be DC protected.  
Check whether amplifiers work after removing RCA-Input.  
If amplifiers work, then check DC by checking RCA-input .  
When DC is over 4V at input, try by replacing \*12V source unit .

### DISTORTION & NOISE

- Ⓜ Readjust input level and check the speaker quality at another amplifier.  
Replace poor quality speakers with good quality ones.
- Ⓜ Check amplifiers and headunit's ground contact. all grounds should be common.
- Ⓜ Check Rca Jack, then repalce with new one or reroute Rca Jack.
- Ⓜ Engine noise is caused by poor grounding of amplifiers, headunit, other components, battery or alternator, so please check all grounding connection.

### POOR BASS RESPONSE

- Ⓜ Please check speaker cables and reverse polarity.

